



The Silencer

Desktop Acoustic Enclosure

FEATURES

- Enclosure provides **25 - 35 dB of Noise Reduction**
- Seven Layers of **Acoustic Damping Material**
- Damped Cable Ports on **Both Sides**
- **Reversible** (right/left) Side-Opening Front Door
- Side-Mounted **Lifting Handles**

APPLICATIONS include

- SPM (AFM & STM)
- Optical Microscopy
- Optical and Stylus Profilometry

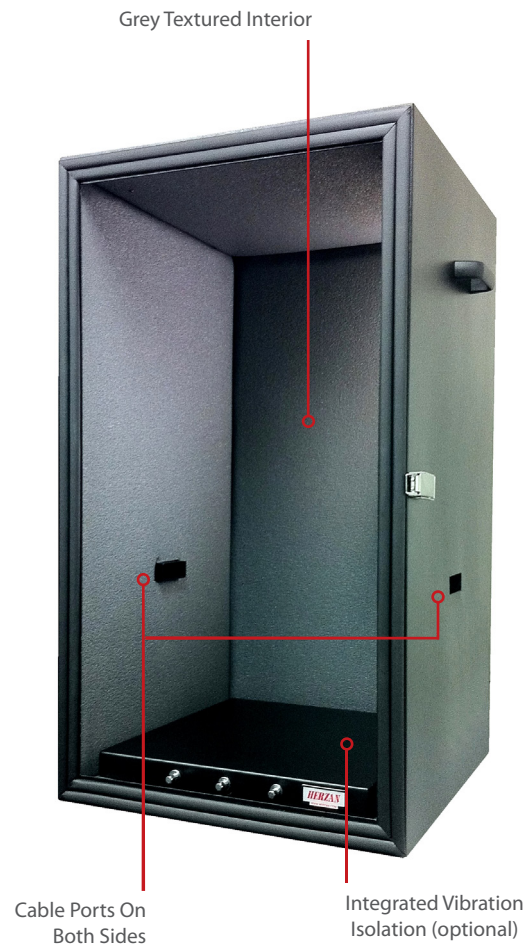

Herzan LLC

23151 Alcalde Drive, Ste B-3 • Laguna Hills, CA 92653
telephone: 949-363-2905 • fax: 949-340-9751
www.herzan.com • sales@herzan.com



The Silencer

Desktop Acoustic Enclosure

OPTIONS

- Integrated Vibration Isolation (active or passive)
- EMI Shielding
- Gas Purge
- Temperature Stability
- Acoustic Performance Boost
- Custom Sizes and Colors

SPECIFICATIONS

- Internal Dimensions:
W 18" x D 19.8" x H 34.5"
- External Dimensions:
W 20.1" x D 24.1" x H 36.3"
- Enclosure Weight: 44 kg / 97 lbs
- Sound Loss:
31.6 dB @ 100 Hz
34 dB @ 1000 Hz
33 dB @ 5000 Hz

ACOUSTIC ISOLATION PERFORMANCE

Sound Pressure Loss = dB without enclosure - dB with enclosure

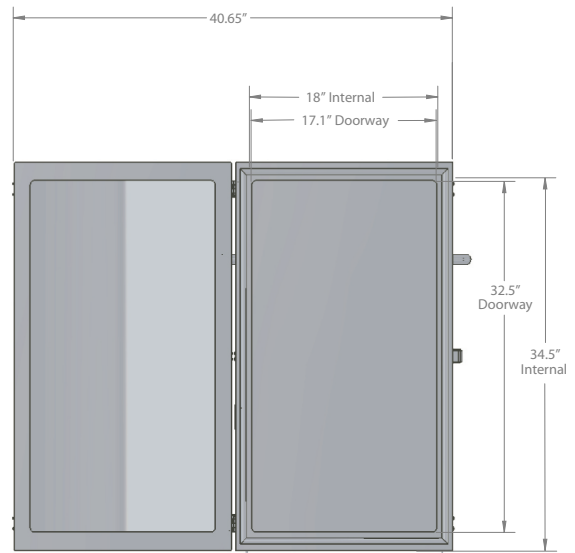
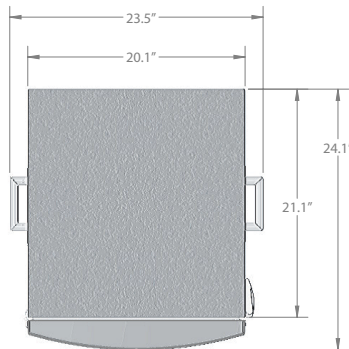
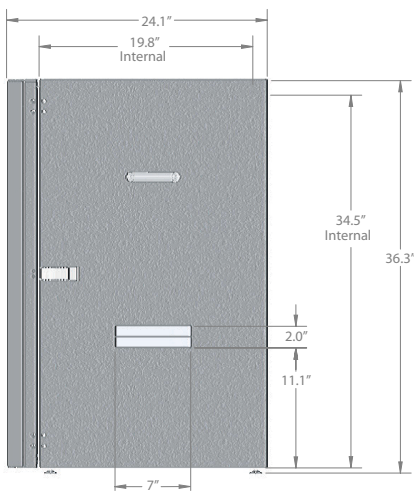
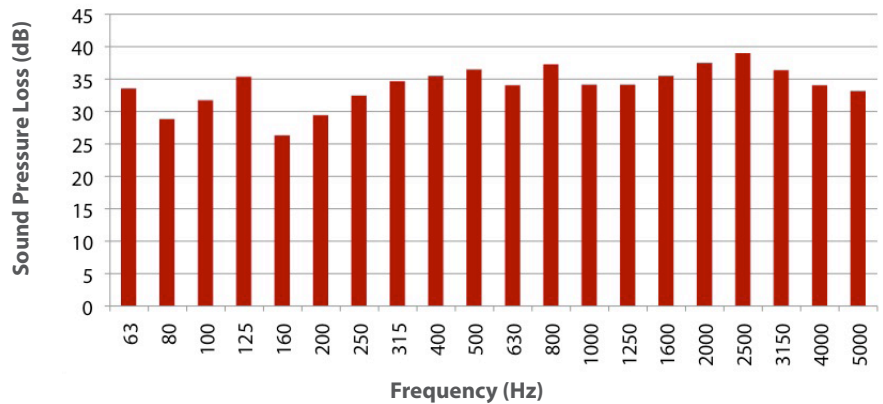

Herzan LLC

23151 Alcalde Drive, Ste B-3 • Laguna Hills, CA 92653
 telephone: 949-363-2905 • fax: 949-340-9751
 www.herzan.com • sales@herzan.com